

## HM314 Series

### Features



- Intel® Alder Lake-N N97/i3-N305
- Single-channel DDR5-4800, with a maximum memory capacity of 16GB
- Dual display of DP&HDMI
- 5x LAN (4x Intel i210; 1x Realtek RTL8111H) 1x RS-232/422/485; 1x RS-232
- 3x USB 3.0; 3x USB 2.0
- Support expansion of 4G/5G and Wi-Fi 6 wireless communication modules
- DC9-36V, support optional UPS module expansion

### Product Parameters

| Product Parameters |          |  |
|--------------------|----------|--|
| System parameters  | CPU      | Intel Alder Lake-N N97/i3-N305                                     |
|                    | Chipsets | Intel® SoC Integrated  |
|                    | BIOS     | AMI 128Mbit SPI Flash  |
|                    | Memory   | 1x SODIMM DDR5, MAX 16GB   |
|                    | Storage  | 1x M.2 M-Key 2280, SATA 3.0  |
| External I/O       | Display  | 1x DP, MAX 4096 x 2304@60Hz<br>1x HDMI, MAX 4K/2K@60Hz             |
|                    | LAN      | 4x LAN, Intel® i210 GbE<br>1x LAN, Realtek RTL8111H GbE            |
|                    | COM      | 1 x RS-232/422/485, 1 x RS-232                                     |
|                    | USB      | 3x USB3.0; 1x USB2.0   |
| Others             | REMOTE   | Support remote switching, integrated in the power supply part      |
|                    | RESET    | Support BIOS reset by long-pressing the power button when shutdown |

| Product Parameters       |                       |  |
|--------------------------|-----------------------|--|
| Internal Expansion       | USB                   | 1xInternal USB2.0(pin); 2x internal USB 2.0 Type-A   |
|                          | M.2                   | 1xM.2 3052, support 4G/5G; 1xM.2U2230, support Wi-Fi |
|                          | SIM                   | 1 x Nano SIM   |
| System                   | OS                    | Windows 10/11.centos 8.ubuntu 20.04/22.04            |
| Power supply             | Input voltage         | DC9~36V  |
|                          | Power                 | MAX 60W  |
| Mechanical parameters    | Installation          | Wall-mounted installation (rail optional)            |
|                          | Dimensions            | 180 x 165 x 67 mm                                    |
|                          | Net weight            | 2kg  |
| Environmental Parameters | Operating temperature | 0~60°C, with an air flow of 0.7 meters per second    |
|                          | Storage temperature   | -40°C ~85°C, 60°C @ 95% (non-condensing)             |
|                          | Relative humidity     | 10 ~ 95% @ 40°C(non-condensing)                      |
|                          | EMC                   | CE、FCC Class B                                       |

## HM314

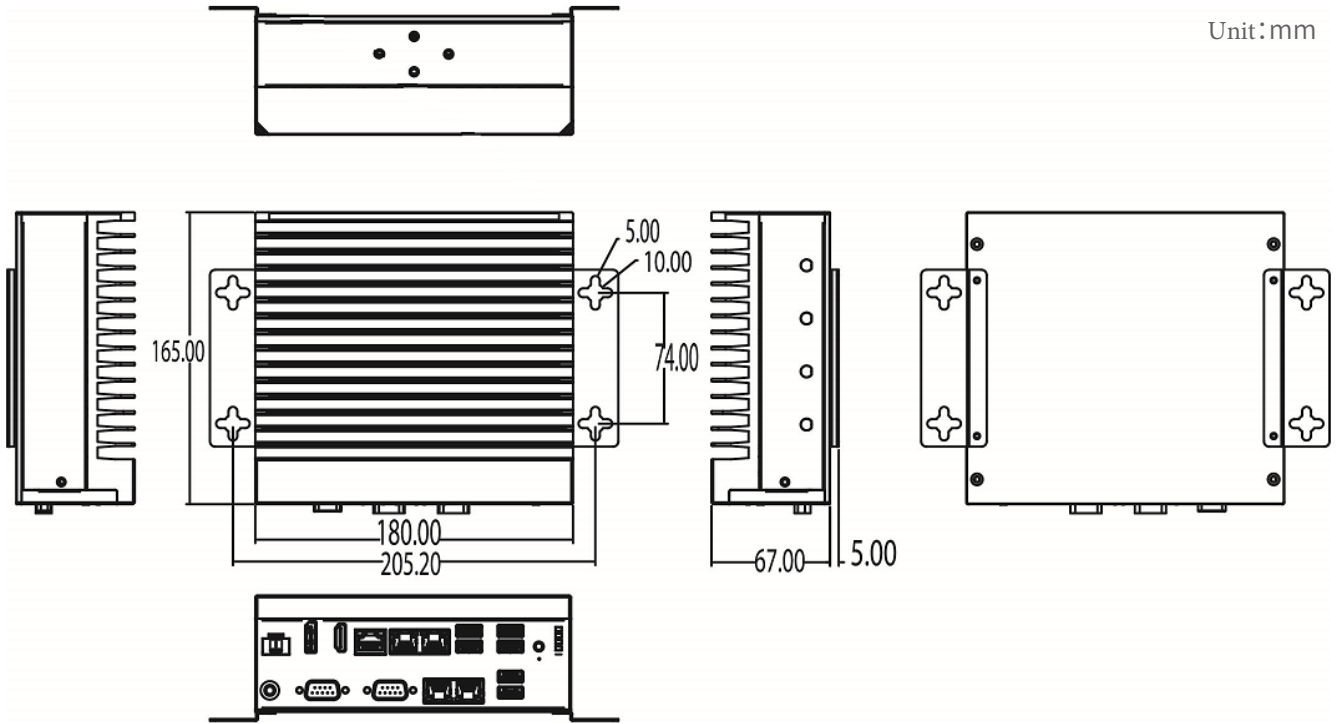

## Ordering Information

| Model       | CPU     | MEM    | SSD                  | HDD ( 2.5") | Expansion module      |
|-------------|---------|--------|----------------------|-------------|-----------------------|
| HM314-N9XXX | N97     | 8G/16G | 128G/256G/512G/1T/2T | /           | WIFI module/5G module |
| HM314-S3XXX | I3-N305 | 8G/16G | 128G/256G/512G/1T/2T | /           | WIFI module/5G module |

\*XXX represents the memory capacity 2<sup>X</sup>, solid-state drive capacity 2<sup>X</sup>, and mechanical hard drive capacity XT in sequence